



SONOMATIC

DATA SHEET

DIVER & ROV DEPLOYED (AUTOMATED UT) NAUTILUS SYSTEMS

THE PURPOSE

This document is composed to assist our clients and the supply chain with a high-level understanding of the benefits and services associated with our Nautilus systems.

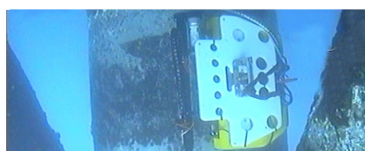
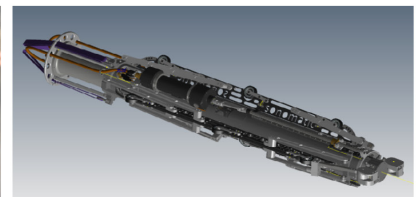
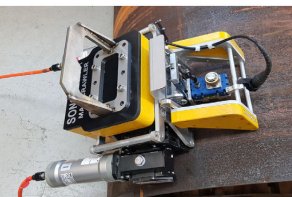
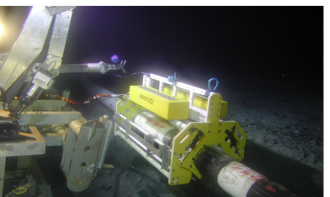
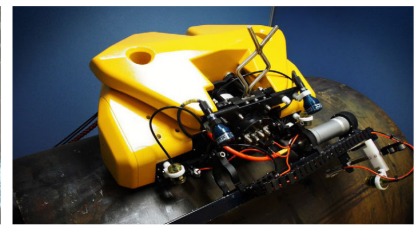
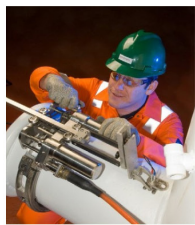
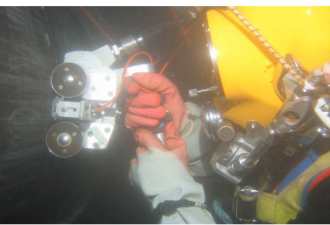
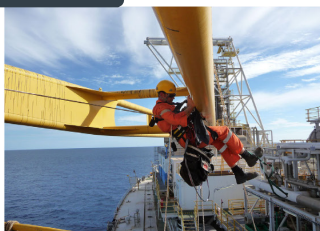
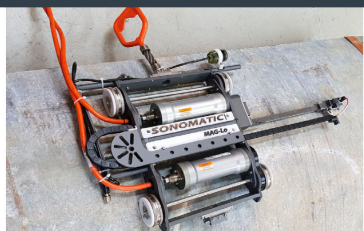
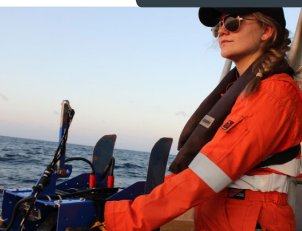

NAUTILUS SYSTEMS

The diver and ROV deployed Nautilus systems are motorised manipulator units designed for subsea inspection of pipework and tubulars at depths of up to 250 meters. These systems are equipped with ultrasonic imaging capabilities and can be controlled remotely from the surface.

DIVER DEPLOYED NAUTILUS SYSTEM

The manipulator is diver deployed and interfaced with a Sonomatic Microplus digital ultrasonic imaging system. It allows for a wide variety of ultrasonic inspection techniques, including corrosion mapping, pulse-echo angle shear wave, and time-of-flight diffraction (TOFD). With its adaptable design,

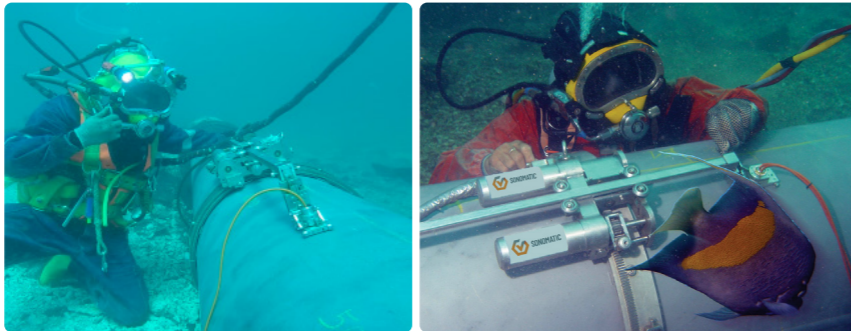

it can be used to inspect various components for pipewall corrosion mapping, pipe weld inspection, flange weld inspection, complex geometry welds (nozzle hop tap welds), and pipe ovality inspections (including measurements of surface dents). The system provides precise positioning and movement of transducers through a rigid, hinged collar attached to the component. It has a low profile design, allowing for a minimum clearance of 120 mm from the component surface.

ROV DEPLOYED MAG-NAUTILUS SYSTEM



On the other hand, this unit is ROV deployed that harnesses power and data communication feeds from the ROV, making it a versatile system. Similar to the diver deployed system, it is interfaced with a Sonomatic Microplus digital ultrasonic imaging system and offers a wide range of ultrasonic inspection techniques including corrosion mapping, pulse-echo angle shear wave/phased array, time of flight diffraction (TOFD) and ACFM.

The ROV Mag-Nautilus system is adaptable and can inspect various components for pipe wall corrosion mapping, pipe weld inspection, flange weld inspection, complex geometry welds (nozzle hot tap welds) and Merlin type connectors. It is neutrally buoyant in water, weighing 21 kg in the air and can be manipulated with small observation class ROVs such as an LBV300, for manipulation in tight restricted locations.

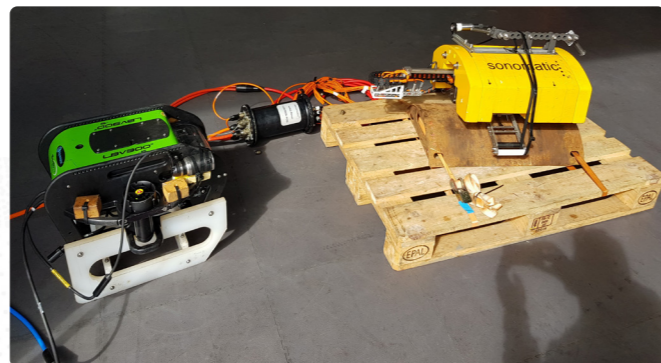

The system uses 4x magnetic wheels, attraction force ≈ 40 kg to adhere to the inspection surface and can inspect 360 degrees around the component. The transducers can be moved in increments down to 1 mm (or smaller) both circumferentially and axially around the component taking measurements at every location. The axial stroke is dependent on the application and access, but stroke lengths of 500 mm are typically applied. It also has an auto-release mechanism for easy removal when working with smaller ROVs for protection during deployment/recovery.

DIVER & ROV DEPLOYED NAUTILUS SYSTEMS

The Nautilus system can deliver many inspection heads/techniques to perform various inspections including:

- ✦ Hyperbaric weld repairs (diver deployed system)
- ✦ Hot Tap nozzle weld inspections
- ✦ Pipeline IP Verification using corrosion mapping and TOFD
- ✦ Structural weld inspection
- ✦ Localised dent measurement

Both systems have the capability to move the transducers in increments as small as 1mm, allowing for precise measurements at every location. The axial stroke length varies depending on the application and access, but a typical stroke length of 500 mm is applied. They can be applied to a range of component geometries and offer various inspection heads and techniques.

In summary, the diver deployed Nautilus system and ROV deployed MAG-Nautilus system are advanced subsea inspection tools that provide accurate and efficient inspections of pipework and tubulars at depths of up to 250 meters. They offer a wide range of ultrasonic inspection techniques and can be adapted to inspect various components for different purposes.

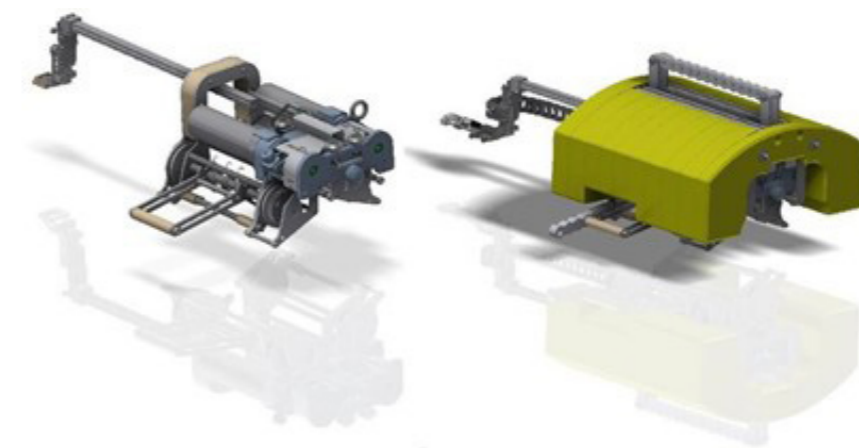

QA AND HS&E

Sonomatic operate under an integrated QHSE management system and are committed to the highest quality and safety of service provision | ISO 9001: 2015: 00007140 | ISO 14001:2015:00037371 | ISO 45001:2018:00037372 | ISO 17020: 2012: 4276 | Achilles FPAL Verified: 076712 | SEQual 1988 | British Safety Council Member: S0388440 |



CONTACTS

EUROPE AND AFRICA

Graham Marshall

Subsea Project Manager
T: +44(0)1224 823 960
E: Graham.Marshall@sonomatic.com

Stuart Ley

Topside Project Manager
T: +44(0)1224 823 960
E: Stuart.Ley@sonomatic.com

Danielle Gunns

Project Delivery Manager (Warrington)
T: +44(0) 1925 414 000
E: Danielle.Gunns@sonomatic.com

Charles Loader

General Manager
T: +44(0)1925 414 000
E: Charles.Loader@sonomatic.com

John Lilley

Senior Technical Consultant
T: +44(0)1925 414 000
E: John.Lilley@sonomatic.com

AUSTRALASIA

Jonathan Millen

Australia West Coast Project Manager
T: +61 415 850 346
E: Jon.Millen@sonomatic.com.au

Judd McCann

Australia East Coast Project Manager
T: +61 488 442 019
E: Judd.McCann@sonomatic.com.au

Zach McCann

South East Asia Regional Manager
T: +61 404 797 670
E: Zach.McCann@sonomatic.com.my

Alex Cesan

Australia & South East Asia General Manager
T: +61 498 442 666
E: Alex.Cesan@sonomatic.com.au

AMERICAS

Esteban Cesan

General Manager Americas
T: +1 832 977 0303
E: Esteban.Cesan@sonomatic.com

MIDDLE EAST

Gordon Reid

Regional Manager
T: +971 26 580 708
E: Gordon.Reid@sonomatic.com

