

SPECIALIST PACKAGE

REMOTE INTERNAL INSPECTION FACILITY REVIEW AND PLANNING

THE PURPOSE

This document has been prepared to help our clients and the supply chain understand the technical capabilities, benefits and services associated with our world-leading RII review and planning services.



SONOMATIC

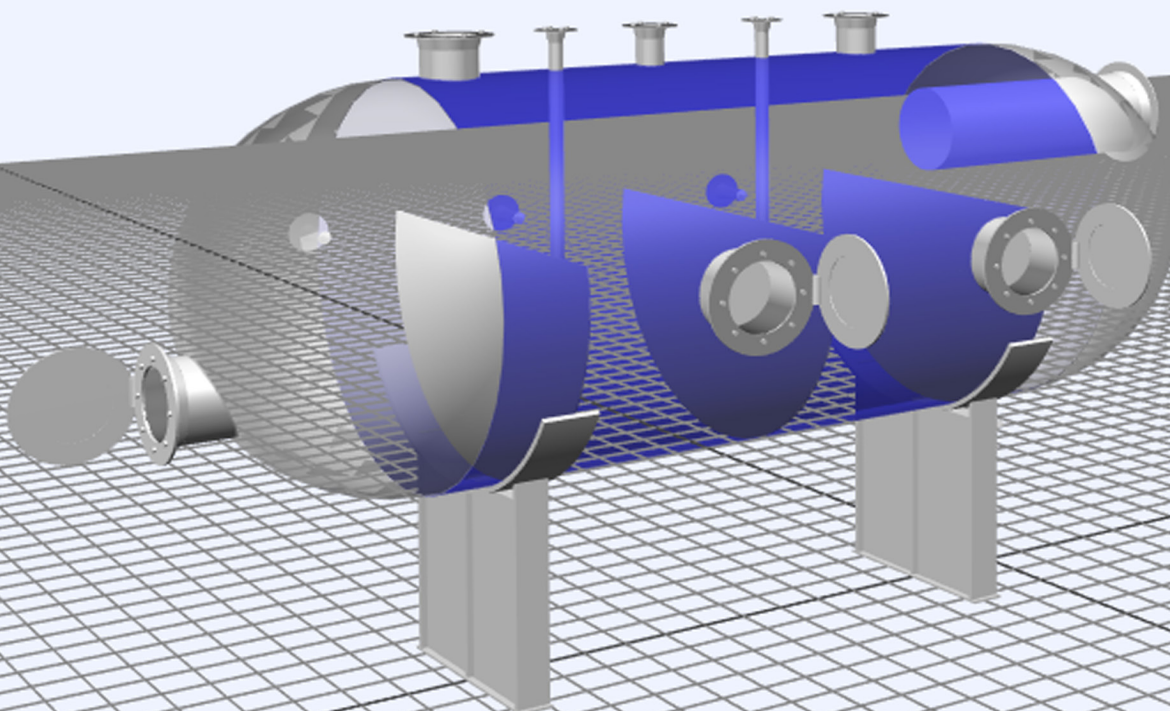

KEY CONTACTS

SONOMATIC

Sean Peters

Project Manager - Europe and Africa

T: +44 (0) 1925 414 000 | M: +44 (0) 7386 807 346

E: Sean.Peters@sonomatic.com

Alex Cesan

General Manager - Australia and NZ

T: +61 498 442 666

E: Alex.Cesan@sonomatic.com.au

Zach McCann

Region Manager - South East Asia

T: +60 361 581 185 /1180

M: +60 12 555 1569 / +61 404 797 670

E: Zach.Mccann@sonomatic.com.my

Charles Loader

General Manager - Europe and Africa

T: +44 (0) 1925 414000 | M: +44 (0) 7376 714765

E: Charles.Loader@sonomatic.com

Esteban Cesan

President - Americas

T: +1 832 977 0303

E: Esteban.Cesan@sonomatic.com

Clayton Webb

Regional Manager - Middle East, Caspian & Black Sea

T: +971 2658 0708 | M: +971 50 313 9254

E: Clayton.Webb@sonomatic.com

AUAV

James Rennie

Managing Director

T: +61 1300 738 521 | M: +61 497 070 576

E: James.Rennie@auav.com.au

Jamie Holyoak

General Manager

T: +61 1300 738 521 | M: +61 473 136 614

E: Jamie.Holyoak@auav.com.au

Barry Nixon

Operations Manager - UK

T: +44 (0) 1224 823960

E: Barry.Nixon@auav.co.uk

Luke Campbell

Operations Manager - Western Australia

T: +61 1300 738 521 | M: +61 467 677 886

E: Luke.Campbell@auav.com.au



www.sonomatic.com